



building inspectors or assume any other identity. There are many different kinds of confidence games. To avoid becoming a victim:

- Beware of friendly strangers offering goods or services at low rates.
- Beware of friendly strangers who tell you they found money and want to share it with you.
- Be suspicious of telephone calls from persons claiming to be bank officials who ask you to withdraw money from your account for any reason. Banks communicate in writing on business transactions.
- Be alert to any scheme that involves removing your savings or other valuables from safekeeping and turning them over to anyone.
- Be suspicious of fortune tellers, "readers", "advisors", etc. If you are asked to turn over money or valuables, notify the police.
- Don't hesitate to notify police of any suspicious situations.

REMEMBER:

**YOU DON'T GET SOMETHING
FOR NOTHING**



NEW YORK CITY POLICE DEPARTMENT

SAFETY TIPS FOR THE OLDER PERSON



FREE SECURITY SERVICES FOR YOUR HOME-OFFICE-OR BUSINESS

SECURITY SURVEYS: confidential surveys conducted for burglary, robbery, larceny and other types of loss.

LECTURE PROGRAM: crime prevention lectures dealing with street crime and property crime can be arranged for your business, civic or social organizations.

SEND TO:

Community Affairs Bureau
Crime Prevention Section
34½ East 12th Street
New York, N.Y. 10003
(212) 614-6741

REQUEST FOR:

Security Survey _____

Guest Speaker _____

REQUESTOR:

Name _____

Address _____

Tel. # _____

You can help us fight terrorism,
report suspicious activity to:

**1-888-NYC-SAFE
1-888-692-7233**

COMMUNITY AFFAIRS BUREAU
CRIME PREVENTION SECTION
34½ East 12th Street
New York, N.Y. 10003

AT HOME

Equip your door with a deadbolt or drop bolt lock. The lock should also have a highly pick-resistant cylinder protected by a guard plate.

The door viewer should be of the wide-angle type which gives a fuller view of the outside area.

Do not open door until you are sure of the identity of your visitor(s).

Always lock door when leaving, even to put out trash, pick up mail or walk the dog.

Do not leave house key under mat, in mailbox or in any other area near the door.

If on returning you find the door open or tampered with, do not enter. Leave immediately and notify police.

If you lose your keys or they are stolen, replace lock cylinders immediately.

For fire escape windows the Fire Department approved "ferry" gates are recommended. Any key operated gate is against the law on fire escape windows.

A licensed locksmith will show you a variety of window locks that are available for all types of windows.

If awakened at night by an intruder, lie still, try not to panic and at first opportunity call the police.

Don't volunteer any information to unknown callers on the telephone.

ON THE STREET

Travel and shop with company whenever possible during the daytime as well as nighttime. There is greater safety in numbers.

If possible avoid carrying a pocketbook. When carrying a pocketbook, keep keys and cash in garment pockets or hidden elsewhere on your person.

When walking, and especially when shopping, hold your pocketbook at all times and keep your hand on the clasp to foil pickpockets.

When in a theatre or restaurant, keep your pocketbook on your lap. Do not place it on the floor, on another seat or on the back of a chair.

Take only necessary items when going out, leave charge cards at home unless you intend to use them. Carry only the cash needed. Keep personal papers in a safe place at home or in a safe deposit box at your bank.

If your pocketbook is snatched, let it go. ***DON'T FIGHT FOR IT.***

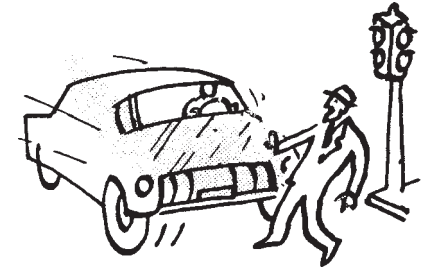
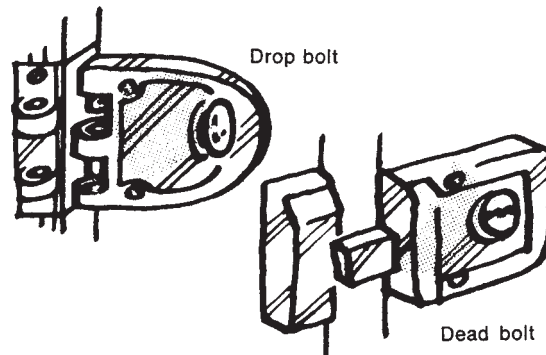

WHEN WALKING

Older pedestrians (ages 70+) accounted for 18 percent of all pedestrian fatalities in 2001. In 2000, the death rate for this age group was higher than any other age group. Source "National Center for Statistics and Analysis, National Highway Traffic Safety Administration and the U.S. Department of Transportation".

- Never cross against the light.
- Cross at the corner, never between parked vehicles or in the middle of the block. Stay within crosswalk.
- Watch for cars turning into crosswalk. Before crossing, make certain that all cars have stopped.
- Never assume the driver will see you or be able to stop in time. Your safety is your responsibility.

CONFIDENCE GAMES

"Con artists" are smooth-talking criminals who aim to separate you from your money through trickery and deceit. They can be men or women working alone, in pairs or in groups. They may stop you on the street, call on the phone or ring your doorbell. They may pretend to be repairmen,